

A photograph of an industrial facility, likely a refinery or chemical plant, with several large silver storage tanks and complex piping. In the foreground, there is a field of golden corn. A white tanker truck is driving on a road in the background. The sky is blue with some clouds. The entire image is framed by a thick black border and tilted slightly to the right.

eX Series

Campaign
Booklet
2023

Overview

Roper Pump Company is excited to announce its latest innovation: the eX Series. This new breed of eXtreme-condition crude oil, condensate, and abrasive liquids pump has the versatility to pump multiple viscosities while reducing costs, increasing speeds, and extending pump life.

Touting alloy steel shafts that are surface hardened for durability, wear-resistant bushings, and leak-proof seals, the eX Series is available in the following sizes: 3X48, 3X65, 4X48, 4X65.

If your customers would find value in superior flow rates, the ability to handle hydrocarbons from condensate to heavy crude to abrasive fluids, reduce downtime and maintenance, and increase the service life of the pump, then Roper's eX Series is their answer.

We are eager to partner with you and promote the eX Series to your customers. This comprehensive booklet details the communication and marketing efforts Roper Pump will initiate using our existing contact database. Please take a moment to review the booklet as there will be resources offered that are available for you and your sales team to utilize. Together, we can capitalize on the immense potential of the eX Series and achieve outstanding sales growth in the months to come.

Thank you again for your ongoing commitment to excellence. Let's embark on this exciting journey together!

Email Marketing

SALES EBLASTS

A series of sales eblasts will be sent to Roper Pump's existing contact database. These email templates will be made available to you to distribute to your customers.

NURTURING EBLASTS

Internet leads who submit their email for additional information will also be added to an automated series of nurturing eblasts. These eblasts will communicate eX Series-specific information and nurture contacts through Roper Pump's sales process, ultimately being shared with respective channel partners once the leads are ready to convert to a sale.

POST-PURCHASE EBLASTS

Internet leads who submit their email for additional information will also be added to an automated series of follow-up eblasts which will be initiated 6 months from campaign start. These eblasts will touch base with the customer and inquire about how the pump(s) is performing.

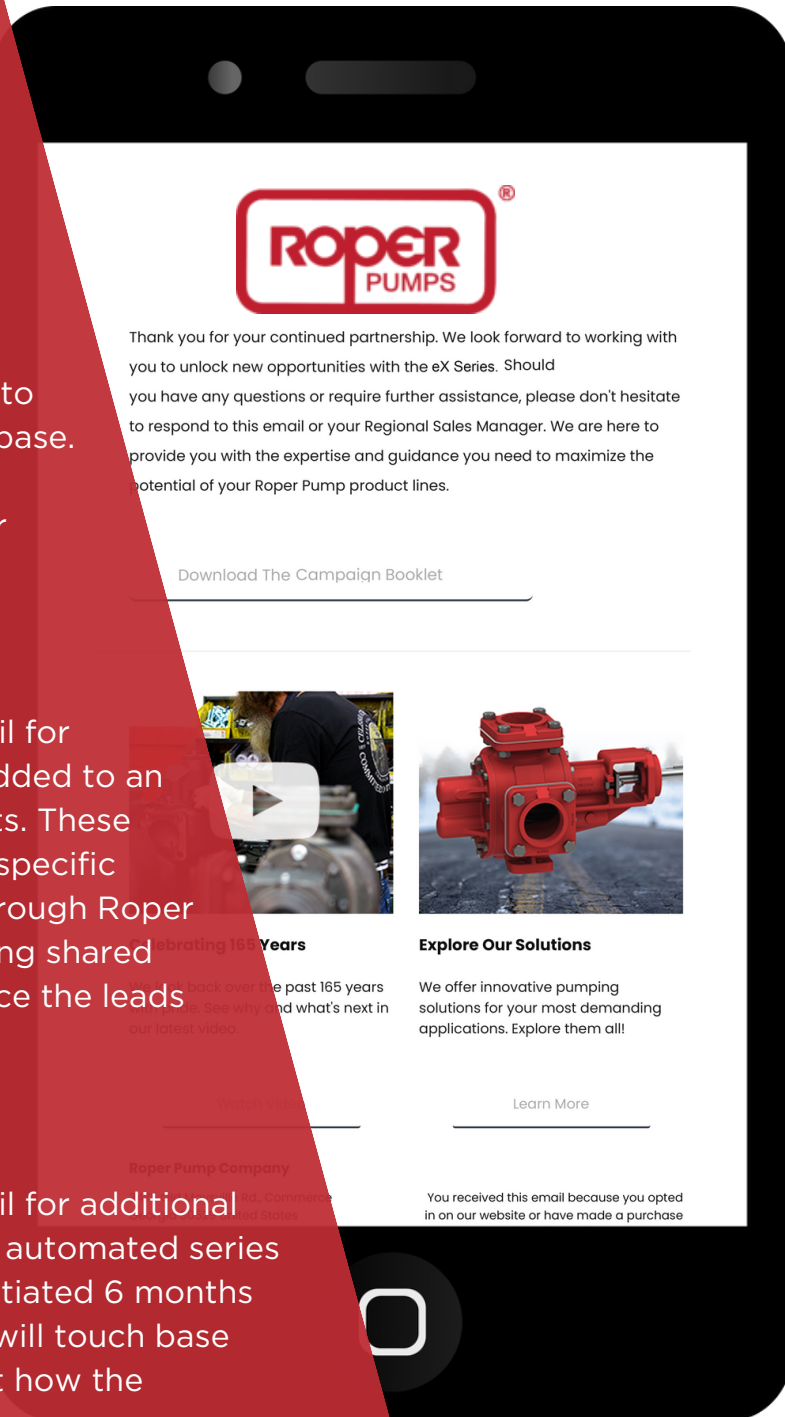

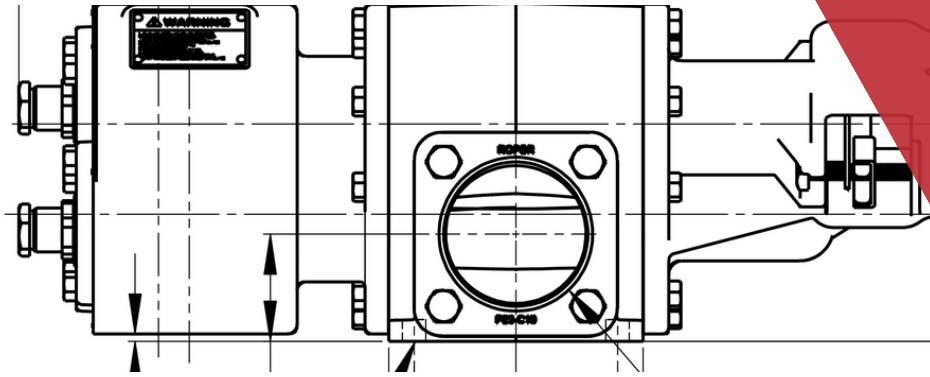

Website

[95]
3.74
LO-DRIVE

[162]
6.39
HI-DRIVE

PRODUCT PAGE

Roper Pump's website has been updated to include eX Series pump-specific information. Visit roperpumps.com/eX-series for more details.

LANDING PAGE & FORM

A landing page has been created to capture internet lead's contact information by way of filling out a form. All Roper Pump marketing initiatives will direct prospects to this landing page URL.

PRESS RELEASE & BLOG POST

A press release and relevant blog post content will be live on our website at the launch of the campaign. This content will be shared organically through other Roper Pump channels such as social media and eblasts.

Online Advertising

Sponsored



roperpumps.com

<https://roperpumps.com/roper/pump>

Roper Pump Company - Pumps That Deliver - Gear Pump Experts

Discover Roper Pump: Elevate your fluid systems. Partner with us today Roper Pump: Maximum productivity with trusted quality for industrial fluid transfer.

PAID SEARCH

We will be utilizing paid search advertising in which our ads will appear more prominently in search engine results with the goal of driving traffic to our website.

These ads will dynamically generate the headlines and ad copy, based on the platform's algorithm, targeting relevant searches based on the user's search and the text that is most relevant to our landing page and domain.

These ad listings appear when users type in keywords we have pre-selected to bid on.

Training & Sales

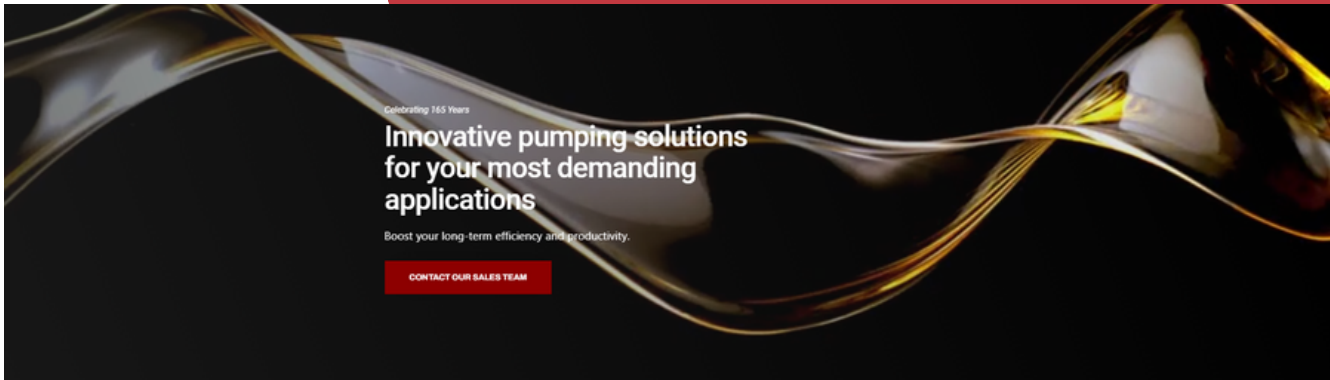

BROCHURE

A sales brochure detailing specifics about the eX Series will be available to download for training and reference during the selling process. This PDF will be available for download.

FACTORY TRAINING

For additional information or to schedule factory training, you can also contact Roper Application Engineers at sales@roperpumps.com or call (706) 335-5551.



Content Marketing

QUIZ

As part of Roper Pump's inbound marketing initiatives, a quiz will be available on Roper's website to assist visitors in seeing if the eX series is a good fit for their application. This quiz link will be available to you and your sales team to share or embed in your communications.

EMAIL SIGNATURE

Roper Pump employees will be adding a graphic to their email signature to promote the series. The email signature will link to the landing page. This graphic will be available for you and your team to download and use.

CASE STUDY

We have received excellent feedback from end-users who have installed and used this pump. We are in the process of collecting this data and compiling it into a case study. This PDF will be available for download upon completion.

CHARTS & INFOGRAPHICS

Technical data sheets and helpful charts and infographics will be incorporated into our communications. These files will be made accessible to you also.

Social Media

ORGANIC POSTS

A series of organic social media posts will be published over the next six months promoting the features, advantages, and benefits of the eX series.

Pre-written copy and supporting graphics will be available for you to download and use in any social media efforts.

We encourage engagement online with our social media pages, and likewise, will engage with any posts you share on your platforms. Below are our social media handles for you to tag in your post copy:

LinkedIn: @RoperPumpCompany

Facebook: @RoperPumpCompany

X (Twitter): @RoperPumpCo



Distributor Launch Kit

Once the distributor launch kit is live on our website, we will send an email notification informing you of how to access the information.

Files will be available in formats compatible with downloading to your PC or mobile device.

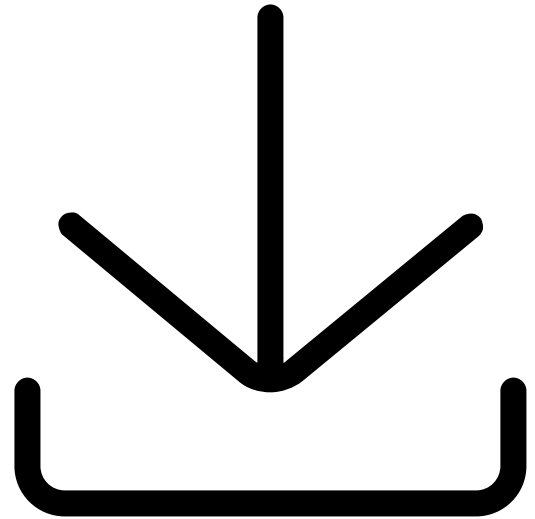

**Explore Distributor
Resources**